

الکتروموتورهای سه فاز صنعتی تک دور با فریم چدنی مطابق با استانداردهای IEC، درجه حفاظت IP55 (۱) مناسب برای کار دائم، روش تهویه IC411 با پروانه خنک کننده و پره‌های روتور، کلاس حرارتی F، فرکانس کار 50HZ و ولتاژ نامی 380V (۲)

تیپ موتور	اندازه فریم	قدرت خروجی		ولتاژ نامی V	سرعت دربارنامی RPM	جریان نامی A	گشتاور نامی N.M	راندمان 70/0 EFF	ضریب قدرت COSφ	جریان راه اندازی راه اندازی نامی	گشتاور راه اندازی گشتاور نامی	گشتاور شکست گشتاور نامی	ممان اینرسی Kg.m ²	وزن برای نوع پایه دار Kg
		KW	HP											
100L4A	100L	2.2	3.0	220Δ/380Y	1405	8.9Δ/5.1Y	14.90	81	0.8	4.5	2.1	2.5	0.004613	30
100L4B	100L	3	4	220Δ/380Y	1420	11.8Δ/6.8Y	20.25	85.5	0.79	5.6	2.7	3.1	0.006274	35
112M4	112M	4	5.5	380Δ/660Y	1420	8.5Δ/4.9Y	26.90	85	0.84	5.5	2.3	2.6	0.011467	44
132M4A	132M	5.5	7.5	380Δ/660Y	1430	11.7Δ/6.7Y	36.73	85	0.83	4.8	2.1	2.3	0.024381	60.5
132M4B	132M	7.5	10	380Δ/660Y	1445	15.8Δ/9.1Y	49.56	86	0.82	6	2.5	2.7	0.031417	73
160L4A	160L	11	15	380Δ/660Y	1455	22.6Δ/13	72.19	87.6	0.83	5	2.2	2.1	0.062502	119
160L4B	160L	15	20	380Δ/660Y	1455	29.8Δ/17.2Y	98.45	88.7	0.85	5.5	2	2.3	0.080486	133
180L4A	180	18.5	25	380Δ/660Y	1460	39.5Δ/22.5Y	121.1	88	0.81	5.8	2.3	2.5	0.1074	180
180L4B	180L	22	30	380Δ/660Y	1456	45Δ/26Y	143.7	89	0.84	5.6	2.3	2.4	0.1285	200
200L4	200L	30	40	380Δ/660Y	1466	55Δ/32Y	194.8	90.7	0.89	5.6	2.5	2.8	0.2069	260
225M4A	225M	37	50	380Δ/660Y	1463	70.2 Δ/40.5Y	240.8	90	0.89	6.6	3.1	2.7	0.3526	337
225M4B	225M	45	60	380Δ/660Y	1458	89.5 Δ/47.7Y	293.7	90	0.85	6.6	2.9	2.5	0.4195	360
250M4	250M	55	75	380Δ/660Y	1478	102.1 Δ/59Y	355.5	92	0.89	6.7	2.5	2.8	0.6045	452
280M4A	280M	75	100	400Δ/690Y	1480	143 Δ/82.5Y	484.2	89	0.85	7	1.8	2.2	0.94	622
280M4B	280M	90	125	400Δ/690Y	1480	165Δ/95Y	581	90	0.86	7.8	3.2	2.8	1.1499	687
315S4A	315S	110	150	400Δ/690Y	1486	212Δ/122Y	705.93	93.3	0.82	5.8	1.7	2.5	1.8827	830
315S4B	315S	132	180	400Δ/690Y	1484	244Δ/141Y	845.98	92.4	0.84	7	2	2.4	2.2195	930
315S4C	315S	160	220	400Δ/690Y	1488	290Δ/167Y	1025.43	93.8	0.87	6.3	2	2.1	2.6236	964
315M4	315M	185	250	380Δ/660Y	1490	332.5Δ/192Y	1185.65	95	0.89	6.8	2.2	2.1	3.0349	1100
315L4A	315L	200	270	400Δ/690Y	1487	365Δ/211Y	1283.51	95.1	0.85	6.5	2.1	2.2	3.3044	1150
315L4B	315L	250	340	380Δ/660Y	1488	444.3Δ/256.5Y	1604.38	95	0.9	6.8	2.2	2	4.0594	1200
355S4A	355S	250	340	400Δ/690Y	1483	439Δ/253Y	1610	95.1	0.88	6.5	1.9	2.3	5.3	1420
355S4B	355S	315	430	380Δ/660Y	1490	553.6Δ/319.6Y	2018.81	95	0.91	7	1.9	2.7	7.3	1760
355L4A	355L	355	485	380Δ/660Y	1487	623.9Δ/360.2Y	2279.76	95	0.91	7.3	2	2.7	8.5	1900
355L4B	355L	400	544	380Δ/660Y	1490	703Δ/406Y	2563.57	95	0.91	7	1.9	2.7	9.2462	2060
400M4A	400M	450	600	380Δ/660Y	1490	825Δ/476Y	2884	95.6	0.86	6.9	2	2.5	11.29	2420
400M4B	400M	500	670	380Δ/660Y	1491	922Δ/532Y	3202	95.8	0.85	7.8	2.4	2.8	12.14	2530
400L4	400L	560	750	380Δ/660Y	1490	1026Δ/592Y	3590	95.9	0.86	6.7	2	2.4	14.08	3480
400L4	400L	630	845	380Δ/660Y	1491	1139Δ/658Y	4036	96.1	0.86	7	2.5	2.7	15.47	3720

1500 RPM - 4 POLE

موتور

مشخصات ابعادی الکتروموتورهای سه فاز صنعتی با فریم چدنی (پایه دار)

سایز فریم 315-355

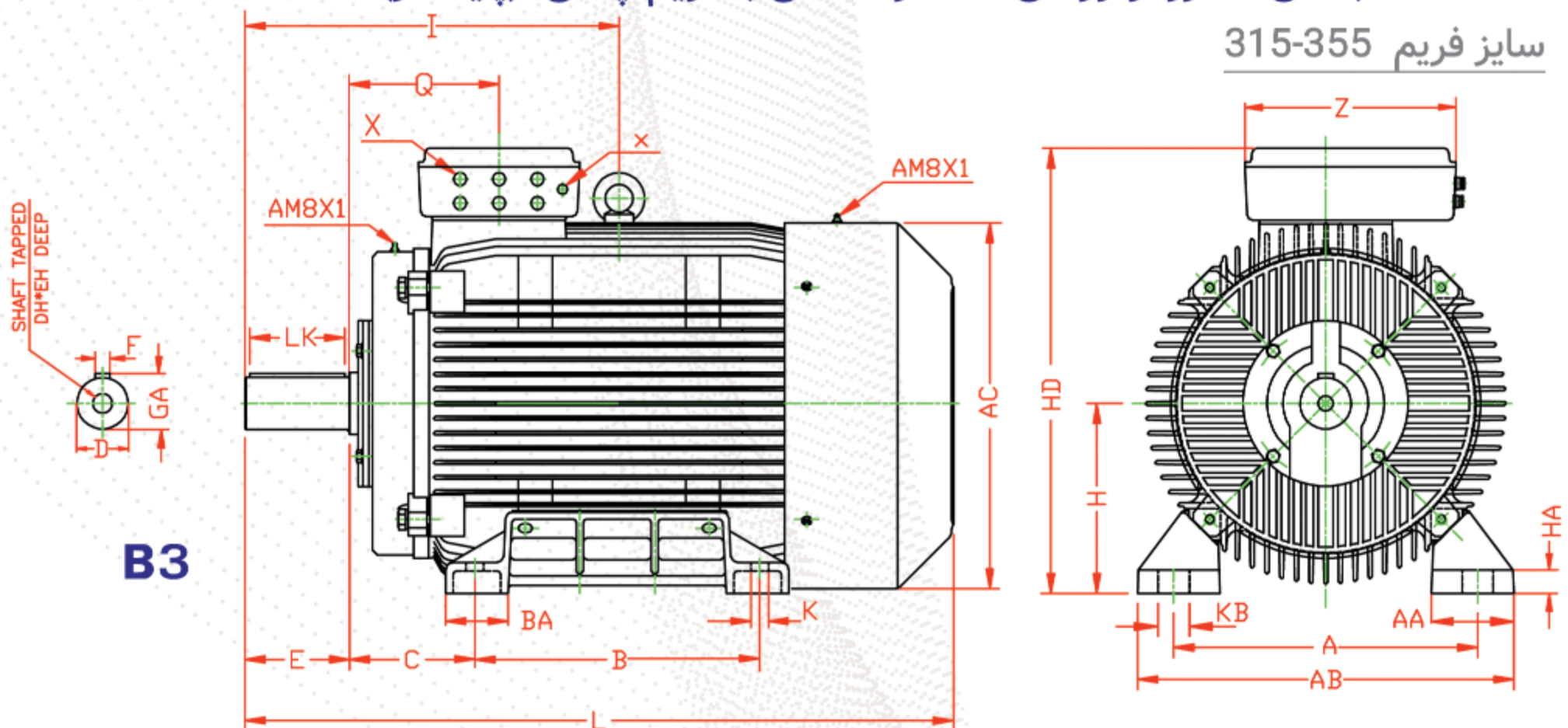

B3

TYPE	A	AB	AC	Z	B	BA	C	D	E	F	GA	I	Q	K	H	HD	AA	HA	KB	LK	DH x EH	L	X,x	
315 S2A					406																	1082	6xPg21, Pg11	
315 S2B																								
315 M2A	508	620	611	470	457	100	216	65	140	18	69	589	269.5	28	315	795	126.6	50	28	110	M20x53	1131		
315 M2B																								
315 L2A																								
315 L2B					508																			1222
315 S4A					406																	1082	6xPg21, Pg11	
315 S4B																								
315 S4C	508	620	611	470		100	216	80	170	22	85	589	275.5	28	315	795	126.6	50	28	140	M20x53	1131		
315 M4					457																			
315 L4A																								
315 L4B					508																			1222
315 S6A					406																	1082	6xPg21, Pg11	
315 S6B																								
315 S6C	508	620	611	470		100	216	80	170	22	85	589	275.5	28	315	795	126.6	50	28	140	M20x53	1131		
315 M6					457																			
315 L6					508																			1222
355 S4A					500																	1305		6xPg29, Pg11
355 S4B																								
355 L4A	610	718	690	470		170	255	100	210	28	106	768	320.5	33	355	910	140.2	48	33	180	M24x63	1435		
355 L4B					630																			
355 S6A					500																	1305	6xPg29, Pg11	
355 S6B																								
355 S6C	610	718	690	470		170	255	100	210	28	106	768	320.5	33	355	910	140.2	48	33	180	M24x63	1435		
355 S6D																								
355 L6					630																			1435

ابعاد به میلی‌متر می باشد.

مشخصات ابعادی الکتروموتورهای سه فاز صنعتی با فریم چدنی (پایه دار-فلنج دار)

سایز فریم 315-355

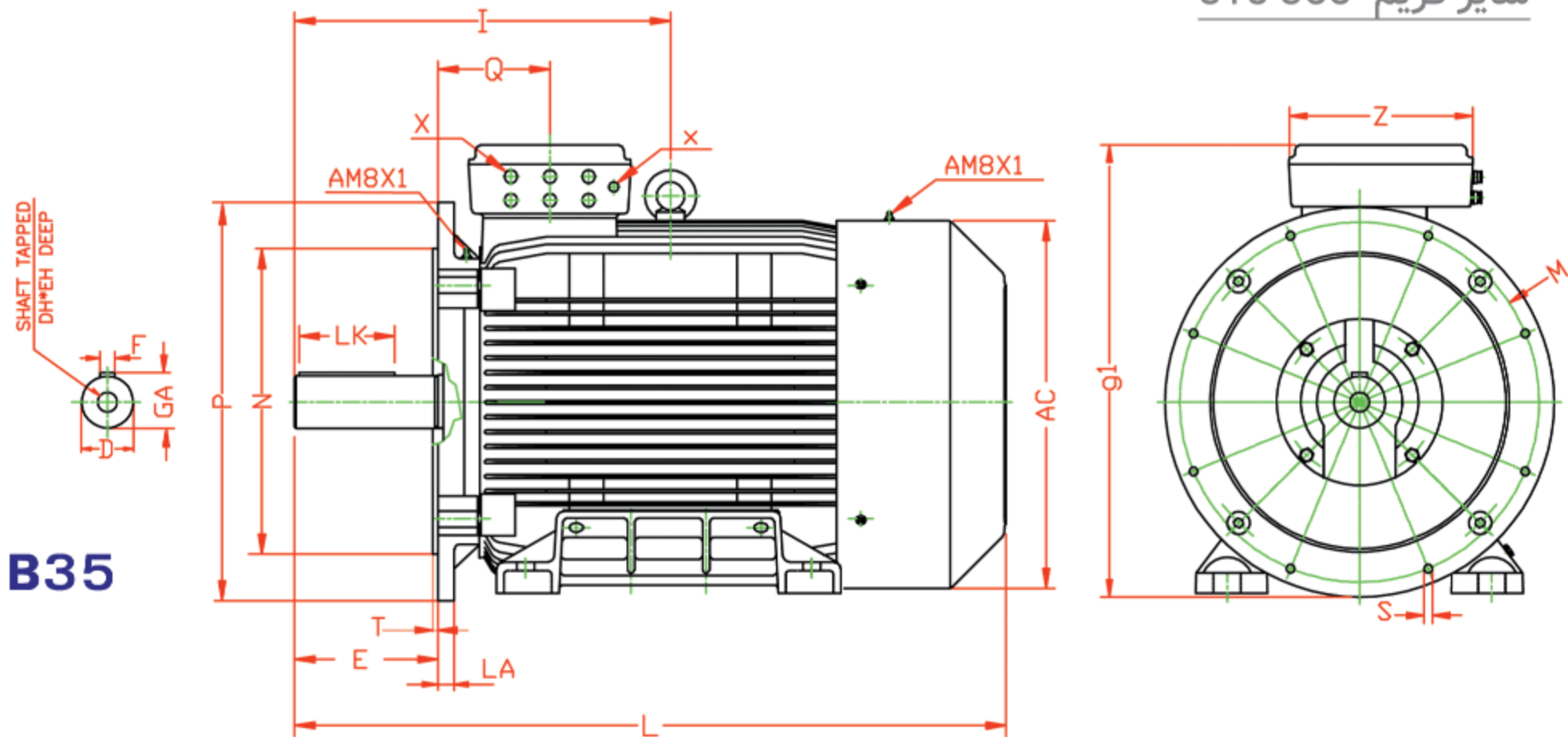

TYPE	D	F	GA	DHxEH	E	L	I	Q	Z	AC	LK	P	N	LA	T	g1	M	S	X,x
315 S2A						1082													
315 S2B																			
315 M2A	65	18	69	M20x53	140	1131	589	269.5	470	611	110	660	550	23.5	6	811	600	21	6xPg21, Pg11
315 M2B																			
315 L2A						1222													
315 L2B																			
315 S4A						1082													
315 S4B																			
315 S4C	80	22	85	M20x53	170	1131	589	275.5	470	611	140	660	550	23.5	6	811	600	21	6xPg21, Pg11
315 M4						1222													
315 L4A																			
315 L4B																			
315 S6A						1082													
315 S6B																			
315 S6C	80	22	85	M20x53	170	1131	589	275.5	470	611	140	660	550	23.5	6	811	600	21	6xPg21, Pg11
315 M6						1222													
315 L6																			
355 S4A						1305													
355 S4B																			
355 L4A	100	28	106	M24x63	210	1435	768	320.5	470	690	180	680	550	21.5	6	952	740	21	6xPg29, Pg11
355 L4B																			
355 S6A						1305													
355 S6B																			
355 S6C	100	28	106	M24x63	210	1435	768	320.5	470	690	180	680	550	21.5	6	952	740	21	6xPg29, Pg11
355 S6D																			
355 L6																			

ابعاد به میلی‌متر می باشد.